



Oilfield Equipment

About Company

Elite Project Engineering is specialized in Design, Engineering and Procurement services for ;

- Oil and Gas
- Petrochemical
- Chemical
- Fertilizer
- Oil Storage Terminals
- LPG Storage Depots
- Power Plants
- Food Processing
- Sugar Mills
- Pharmaceutical

The company is operating under the supervision of senior management having vast experience in Oil & Gas and Petrochemical sectors having its headquarter in China and global offices in United Kingdom, Unites States of America, Canada, Brazil, United Arab Emirates, Pakistan and Nigeria.

In addition to Design and Engineering services, we are capable to take over the complete Procurement (P) part of an EPCC (Engineering, Procurement and Construction and Commissioning) projects either directly from End Users, in Joint Venture with EPCC Contractor and or from EPC Contractor to make sure seamless supply chain management of all project materials from the stud bolts to the process equipment and from the pipeline to the drilling rig depending on the nature of project either its of Oil & Gas (Exploration, Gas Compression, Gas Processing, LPG Extraction, Oil Refinery, Oil Storage Depot) or Petrochemical, Chemical, Fertilizer, Power Plant, Food Processing, Sugar Mill, Pharmaceutical and / or allied industries.

Elite clients always enjoy the seamless services through our highly professional representatives who are assigned delicately to one project at a time to oversee client contracts, supplier contracts and deliveries.

MISSION

Elite is a leader in providing value-added Design, Engineering and Procurement services by creating a successful partnership with all stakeholders. Elite believe in lasting relationships with all stakeholders by exceeding their expectations and gaining their trust through meticulous performance by every member of the organization with the strong commitment to Quality, Health, Safety and Environment (QHSE).

VISION

To be the most preferred and trusted partner of our customers in the industry with special focus and emphasis on delivering quality products & services.

CORE VALUES

Quality: It is our primary focus to produce and deliver superior quality products and services.

Commitment: What we commit, We deliver.

Teamwork: We believe in teamwork which is the most important element to accomplish the set objective.

Customer Satisfaction: To achieve customer satisfaction with our Quality, Commitment and Teamwork.



Drilling Rigs

Drilling Rigs can work independently to meet the different working condition, making it energy-saving and systematically reliable Unique driving head design a Dual structure gear box with finite element stiffness and strength standard design, making it extremely strong.

Submerged design improves the stress condition under max push & pull force.

Driving head adopts main shaft floating design.

Brand-new optimized four-point clamp, the improvement of structure stiffness, strength, cylinder strength and the increase of unscrewing torque making it easy to change the grips, clamp is all-floating and clamping force is steeples adjustable in accordance with the rod size and working condition.

Optional heavy-duty automatic manipulator is Gooding patent to relieve the heavy labor work . Application of intelligent electrical-hydraulic combined control and monitor system.



- Digitally display rig working parameters: rotation torque, rotation pressure, rotation speed, push& pull force, push & pull pressure, push & pull pressure speed, clamping pressure, slurry pressure etc.
- Electrical-hydraulic intelligent monitor and debug system: automatically inspect and debug hydraulic system fault, convenient for the maintenance.
- Electrical-hydraulic combined control system: set constant torque for automatic drilling, avoid the over bend and damage of drill rod by disoperation.
- Application of pendulum electrical control technique for rocky condition, specialize for rocky condition, enhance the efficiency of drilling in the rock.

Truck Mounted Drilling Rig

Scientific research team with excellent technology. While constantly innovating, the company always grasps the development strategy and trend of equipment science and technology in the industry, so that the company's products are always among the best in the world.

The company's products have been used by drilling companies and major drilling rig manufacturers under the three major domestic oil groups, and exported directly to more than 30 countries and regions including Russia, the Middle East, southeast Asia, Europe and the United States along with the drilling rigs, winning unanimous praise.

Elite will continue to follow the principles of integrity, innovation, win-win, the "do industry benchmarking, establish the status and image of state as the pursuit, to strengthen to improve the domestic market at the same time, gradually expanding the international market, through real efforts. Elite construction into healthy, long-term development of the internationalization of enterprises.



Max.hook load :kN	490	700	900	1125	1350	1470	1800	2250
Rated hook load: kN	300	400	600	800	1000	1200	1500	1800
Service depth :m (2-7/8"EU tubing)	2600	3200	4000	5500	7000	8500	-	-
Workover depth: m (27/8"DP)	-	2000	3200	4500	5800	7000	8000	10000
Drilling depth :m (4-1/2"DP)	-	-	-	1000	1500	2000	3000	4000
Engine power:	250 HP	325 HP	385 HP	475 HP	540 HP	700 HP	540X2HP	630X2HP
Drowworks power:	150 HP	250 HP	350 HP	450 HP	550 HP	650 HP	750 HP	1000 HP
Mast height :m	16,18	18,21	31.7	32,34	32,34	34,35	38	39.3
Chassis driving type	6X6	6X6	10X8	10X8	10X8	12X8	14X8	14X10

API Choke Manifold

Choke manifold is a necessary device for controlling well kick and implementing oil-gas well pressure control. When blowout preventer is closed, choke valve can be turned on and off to control certain casing pressures to keep bottom hole pressure a little higher than formation pressure all the time, lest formation fluid should further flow into well. Besides, when well is shut off, choke manifold can be relieved for the realization of soft shut-in. When the pressure rises to a certain level, it can be used to open the well for gushing so as to protect the well.

Choke manifold is composed of choke valve, gate valve, pipeline, pipe fittings and pressure gage, etc. When well pressure rises, the choke valve (it falls into three kinds: Manually adjustable, hydraulic and positive) on choke manifold can be turned on and off to release the fluid to control casing pressure. Gate valve can be used for direct blowout. When casing pressure is pretty high,

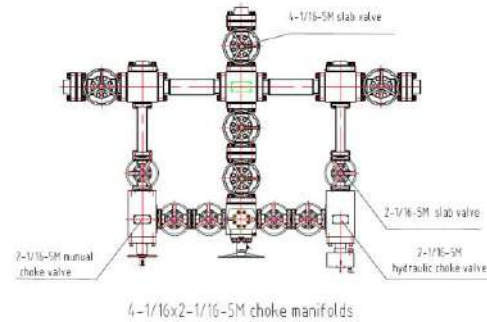

The pressure class of our company's chokes manifold falls into five class: 14MPa, 21MPa, 35MPa, 70MPa and 105MPa. Also, we can design according to customer demand.

Body Material	FORGED/ALLOY/316 SS ETC
Machine Type	API 6A 16c Choke Manifold
Processing Type	FORGING/CASTING
Transmission System	HYDRAULIC
Application	CONTROL THE WELL KICK

Wellhead and Christmas Tree Equipment

Wellhead equipment and Christmas tree are essential for oil and gas exploitation, composed of casing head, tubing head and Christmas tree, used to connect casing string and tubing string, and seal the annular spaces between all casing pipes at all layers and between pipelines.

In addition, it can be used not only to control wellhead pressure and adjust oil (gas) wellhead flow, but also for special operations, such as acid fracturing, water injection and testing, etc. It is made up of casing head, tubing head and Christmas tree.

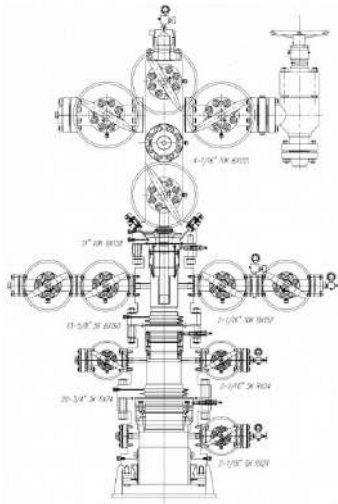
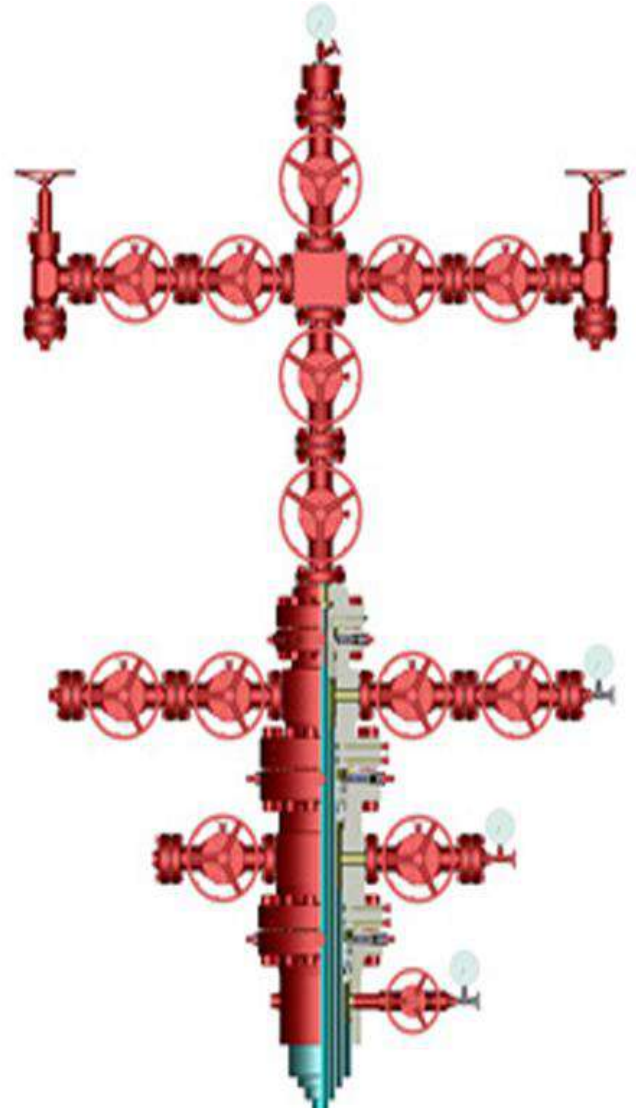

Rated Working Pressure	2000PSI-20000PSI
Rated Working Temperature	-46°C-121°C
Working Medium	OIL, GAS, MUD AND WATER
Material Class	AA-FF
Product Specification Level	PSL1-3

Desander

The equipment shall be suitable for operation with the minimum & maximum ambient temperature of -60C to 550C. The equipment shall be suitable for Drilling fluid "Mud" having specific gravity of 0.9 to 2.6 and API funnel viscosity 35 – 100 seconds/quart. Drilling Fluid (Mud) operating temperature shall be up to 900C. The equipment shall be designed to remove sand/bigger particles up to 74 microns from the drilling fluid (Mud). Feed Line shall be so designed so as to provide adequate pressure (30 – 40 psi) to each cone.



Shale Shaker

The most important solids-control devices are shale shakers, which are vibrating screen separators used to remove drill cuttings from the mud. As the first step in the mud-cleaning/solids-removal chain, they represent the first line of defense against solids accumulation. Shale shakers differ from other solids-removal equipment in that they produce nearly a 100% cut (D100) at the screen opening size.

Many potential problems can be avoided by observing and adjusting the shale shakers to achieve maximum removal efficiency for the handling capacity.

Using screens of the finest mesh to remove as many drill solids as possible on the first circulation from the well is the most efficient method of solids control. It prevents solids from being re-circulated and degraded in size until they cannot be removed.

As much as 90% of the generated solids can be removed by the shale shakers.

Unless the shale shakers are operating properly, and have screens of the finest mesh possible, all other equipment is subject to overloading and inefficient Operation.

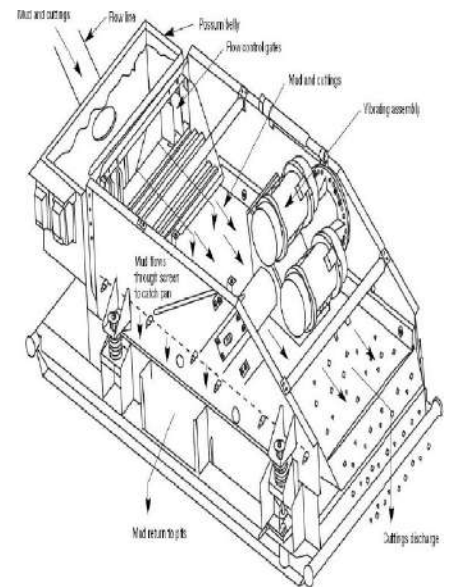

The mud flow should be spread over as much of the screen surface as possible by using feed-control gates located between the possum belly (flow line-to shaker transitional reservoir and the screen surface.

The mud should cover 75% of the screens (About 1 foot from the end of the screens)



Drawworks

1. All bearings that support shaft are roller bearings, and shaft is made of quality alloy steel.
2. Pressure-forced lubrication system.
3. The drum is grooved. The ventilated type of clutch bladders are installed on both high and low speed ends.
4. The brake disc is pressurized water lubricated, and the surface has been hardened by medium frequency induction method to extend its service life
5. The contours of sprocket teeth are hardened with medium frequency induction method.
6. All transmission clutches are of involute spline type.
7. The main brake is either a band type or a disc type. The auxiliary brake is either a eddy current brake or a Eaton brake.

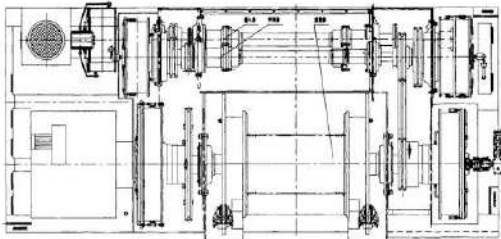

Noeminal depth rating (m)	29 (1-1/8) to 42 (1-5/8)
Rated power (kw)	300- 400 to 2210
Max. fast line pull (KN)	165 to 565
Wrap angle of brake band(degree)	275 to 280
Capacity of sand line drum (D14.5 wire line)	3500 to 6000

Mud Pumps

- The diameter of the suction line must be equal to or exceed the diameter of the pump suction connection. Use as short a suction line as possible.
- Install the suction line in as straight a line possible. If turns are necessary use long radius ells.
- Install a section hose in the suction line to isolate vibration.
- Be sure there are no air traps or air leaks in the suction line.
- Install a charging pump in the suction line.
- Install a suction desurger to prevent mud cavitation.
- Fully open all valves in the suction line before operating the pump. Tips for PREPARATION: If the pump was not completely assembled at the factory, complete the assembly as required.
- Check to be sure the suction and discharge systems have been properly installed
- Remove the cover plates from the power end.
- Inspect the power end for contamination. Clean as required.
- Drain all condensation from the power frame end drain plug Do not attempt to drain condensation from power frame if unit has been filled with lubricant. (why?)
- Install cover plates.
- Check that crankcase drain plug is installed and tight.
- Fill the power end with correct lubricant.



Top Drive

The top drive systems turning drill strings atop today's platforms represent a major improvement over older drilling rig technologies. In part, top drive systems are enabling the use of extended-reach well bores and helping to reduce production costs.

They are however, subject to failures caused by the same conditions that plagued their conventional rotary table and Kelly counterparts.

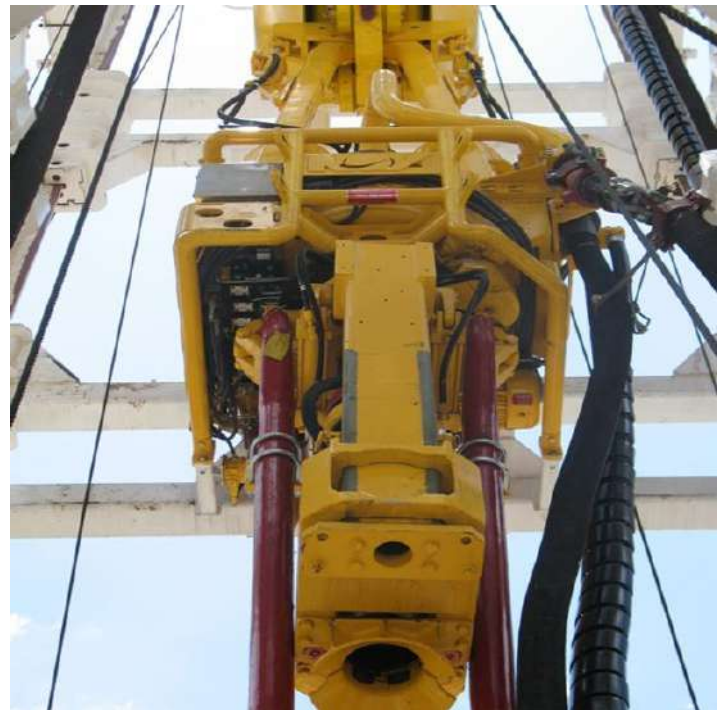
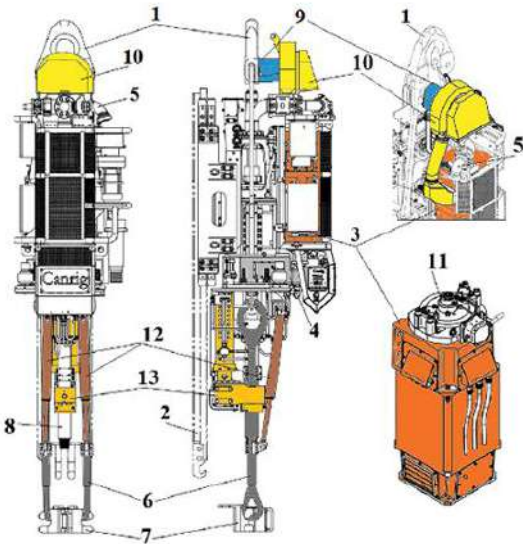

These include mud and lubricant contamination, excessive loads and vibration, or electrical discharges and hydraulic blockages. Elite can help rig operators handle these challenges and more. From specially designed optimized tapered roller thrust bearings to sensitized traction motor units, Elite can enable better top drive reliability and productivity.

Swivel

The is the link between the rotation system of drilling machine, the lifting system and the circulation system, on the one hand, it bears all the weight of the drill column in the well, hangs drill column and ensures the free rotation of the drilling tool, and on the other hand, it is connected with the rotary hose, introduces the high pressure drilling fluid into the rotary drill stem to wash the well in the well bottom.

Swivel function: the rotary hanging drill stem bears a great amount of and all the weights of the drilling tool; it introduces high pressure drilling fluid into the rotary drill column and it is the intersection parts of three working units (lifting unit, rotating unit and circulation unit).

Operation requirements of swivel: the main bearing of the swivel must have sufficient strength and life; high pressure drilling fluid sealing system (or washing pipe assembly) must work reliably, have long life and quick and easy replacement and good oil seals; each bearing parts (including lifting loop, shell and central tube shall have sufficient strength and rigidity).

Bearing system:

central tube and joint, shell, pin roll, lifting loop and main bearing. The drilling tool in the well is added to the central tube through the kelly stem, and the central tube is on the shell by the main bearing seat and transfers the load to the hook through the pin and lifting loop.

Drilling fluid system:

goose neck and wash hose assembly. The high pressure drilling fluid enters the wash hose through the goose neck, flows into the rotating central tube to reach the drill stem, and the upper and lower sealed boxes prevent the high pressure drilling fluid from leaking.



Auxiliary system:

centralizer, anti-jump bearing and motor oil sealing box components. The centralizer and anti-jump bearing play a centralizing function on the central tube, ensure its stability, and limit the swing, in order to improve the working conditions of drilling fluid and machine oil sealing.

Drilling Bits

Elite Provide our customers with the best quality tools, accessories and service in the industry. We are supported by many years of experience, trained professionals and a full machine shop. Reduce the cost ,Speed the drilling ,Guarantee the safety is always our aim.

Regular Sizes	Regular IADC	API Reg Pin
3 7/8"(98.4mm)	126/216/517/537/637	2 3/8
4 5/8"(117.4mm)	126/216/517/537/637	2 7/8
5 1/2"(139.7mm)	126/216/517/537/617/637	3 1/2
5 5/8"(142.8mm)	126/216/517/537/617/637	3 1/2
5 7/8"(149.2mm)	126/216/517/537/617/637	3 1/2
6"(152.4mm)	126/127/216/517/537/617/637	3 1/2
6 1/4"(158.7mm)	126/127/216/517/537/617/637	3 1/2
6 1/2"(165mm)	126/127/216/517/537/617/637	3 1/2
7 1/2"(190mm)	126/216/517/537/637	4 1/2
7 5/8"(193mm)	126/216/517/537/637	4 1/2
7 7/8"(200mm)	126/216/517/537/637	4 1/2
8 1/2"(215.9mm)	117/127/217/437/517/537/617/637	4 1/2
9 7/8"(250.8mm)	117/127/217/437/517/537/617/637	6 5/8
10 5/8"(269.8mm)	117/127/137/217/517/537/617/637	6 5/8
11 5/8"(295.3mm)	117/127/137/217/517/537/617/637	6 5/8
12 1/4"(311.1mm)	114/127/217/437/517/537/617/637	6 5/8
13 5/8"(346.0mm)	127/217/517/537/617/637/737/837	6 5/8
14 3/4"(374.6mm)	127/217/517/537/617/637/737/837	7 5/8
17 1/2"(444.5mm)	114/115/125/215/515/535/537/615/635	7 5/8
20"(508.0mm)	114/115/125/215/515/535/537/615	7 5/8
22"(558.8mm)	114/115/125/215/515/535/537/615	7 5/8
24"(609.6mm)	114/115/125/215/515/535/537/615	7 5/8
26"(660.4mm)	114/115/125/215/515/535/537/615	7 5/8



API 5CT Casing / Tubing

API 5CT is standard technical specifications for steel casing and tubing pipes used for oil wells in petroleum and natural gas industries. We can supply Casing and Tubing manufactured according to API Specification 5CT from mills authorized to use the API Monogram on API Specification 5CT Products.

We offer the standard API range of round thread (STC and LTC) and Buttress Thread casing and API NUE and EUE Tubing as well as with premium connection (metal to metal seal).

We provides a complete range of Casing and Tubing with and without Premium Threads. Tubulars are supplied direct from API-certified mills or from stock of our associated sub-vendors.

- API 5CT Latest Edition
- OCTG from 1.660" to 30" + respective couplings, crossovers and pup joints
- API Grades from H40 to Q125 and 13% CR
- ALL API Standard Weights
- API and Premium Joint Connections
- Special SS and HC grades
- CRA Grades

Types: Seamless & Welded

Standards: API Specification 5CT latest edition at time of manufacture (PSL-1, PSL-2, PSL, 3) ISO 11960:2004, Petroleum and Natural Gas Industries-Steel Pipes for use as casing or tubing for wells

Sizes: Outside Diameter: 1.660" - 30"

Grades: H40, J55, K55, N80, N80Q, L80, C90, C95, T95, P110, Q125, SS95, SS110, 9%CR, 13%CR

Connections:

- STC (short round thread casing)
- LTC (long round thread casing)
- BTC (buttress thread casing)
- XL (extreme-line casing)
- NUE (non-upset tubing)
- EUE (external upset tubing)
- IJ (integral joint tubing)
- Premium Connections
- And almost any premium & gas tight connection



Length: Range 1, Range 2 & Range 3

Protection: External bare and uncoated or externally coated with black / transparent anti rust Mill varnish Plastic or Metal Pin and Box Protectors. Internal plastic coating or sleeves.

Mill Test Certificates: Issued in accordance with API Specification 5CT Latest Edition and Third-Party Inspection can also be performed on request.

Coupling

API Coupling refers to the steel couplings that used in connecting casing pipe and tubing. Also known by OCTG coupling, it is usually manufactured in seamless type, material grade same with the pipe body (API 5CT K55/J55, N80, L80, P110 etc), same PSL or providing higher grades than requested. Same heat treatment also applicable, except there is an special requirements. A casing coupling has internal threads (female thread form) machined to match the external threads (male thread form) of the long joints of casing. The two joints of casing are threaded into opposite ends of the casing coupling.

Steel Grade: H-40, J-55, K-55, C-75, L-80, N-80, C-95, AS-95, P-110, L80-13CR



Pup Joints

Pup Joints are shorter versions of tubing and casing, used to adjust the length of a string to its exact requirements.

There are many different cases where Pup Joints are necessary:

- to reach an exact reservoir depth
- for setting packers at an exact location within the borehole
- to space out your string prior to hanging it

Benefits of Pup Joints:

Pup Joints are a mandatory part of equipment in almost any well. Due to their shorter length, they are typically easier to handle and to use. At the same time, they provide the same performance as the tubing/casing/drill pipe that they are attached to. Pup Joints can be supplied as per requirement of Standard, Grade, Diameter, Length



Heavy Weight Drill Pipe (HWDP)

Heavy Weight Drill Pipe (HWDP) features a tool joint pin and box and a thick-walled tube with a raised central section for wellbore protection of the tube. The central section comes in various designs; slick, spiral, full spiral, or tri-spiral. HWDP can be manufactured as a welded assembly or machined integral from bars. HWDP in the bottom-hole assembly (BHA) provide a gradual transition between drill pipe and drill collars. Its main function is to transfer surface weight-on-bit (WOB) and pipe rotation to the drilling assembly. It also mitigates drill string fatigue and provides directional control of the BHA. In addition, Heavy Weight Drill Pipe can be used to push or force liners/screens down hole during drilling operations.

Standard:

- Pipe body OD from 2-7/8" to 6-5/8"
- API 7.1 & 7.2 specifications
- Welded construction
- Slick central section
- Central upset with two bands each of 3" of hardbanding material to protect casing and prevent wear
- Range 2 and 3 lengths
- API & H90 connections
- Fatigue resistance features (threads cold rolled, API pin stress relief groove, and API box bore-back)
- Phosphate coating on threads and shoulders
- 4" of casing-friendly hard banding on box and pin, and 2x3" on central upset
- Variety of steel grades: API, Sour Service, NS1, Low Temp



Options:

- Integral construction
- Central section design: Spiral, Full-Spiral or Tri-Spiral
- Longer tool joints, providing a maximum re-cut capability for longer service life
- Internal plastic coating
- NS-1 or DS-1 or customers specifications
- High-performance double shoulder connections upon request
- HB 1" taper
- HB extra length
- Higher toughness specification providing greater safety margins in extreme drilling conditions
- Make and Break

Other options upon request

Drill Pipes

- Drill Pipes are in conformance with API 5DP, 7-1 & 7-2 specifications:
- Pipe body OD from 2-3/8" to 6-5/8"
- Range 2 and 3 lengths
- High torque DS connections (upon request)
- API Connections
- And a variety of steel grades:
API: E-75, X-95, G-105, S-135,
Sour Service

Standard Drill pipes available are:

- Pipe body OD from 2-3/8" to 6-5/8
- 87.5 or 95% minimum wall
- All tubes/Grades full length ultrasonic inspected (flut)
- All tool joints exceed API requirements
- Connection threading is performed to API Spec 7-2
- Tool joint markings are applied to customer or API RP7G specifications
- Factory 3 cycle make and break
- Internal Plastic Coating (upon request)
- High quality hard banding solutions upon request
- Full documentation packages provided
- Phosphate-coated threads
- NS-1, DS-1 specifications



Tool Joint

Tool Joint is a heavy coupling element for drill pipe. The pin section of the joint is attached by friction welding to one end of a length of drill pipe, and the female section, or box, is attached to the other end.

Tool joints are usually made of special alloy steel that has been heat treated to a higher strength than the steel of the tube body. The large-diameter section of the tool joints provides a low stress area where pipe tongs are used to grip the pipe. Hence, relatively small cuts caused by the pipe tongs do not significantly impair the strength or life of the joint of drill pipe.

The tool joints, when threaded, provide high-strength, high-pressure connections that are sufficiently robust to survive the rigors of drilling and numerous cycles of tightening and loosening at threads.



A hard-metal facing is often applied in a band around the outside of the tool joint to enable it to resist abrasion from the walls of the borehole.

All tool joints are 100%:

- Magnetic-particle inspected
- Hardness-tested

Drill Collars

Drill Collars are thick-walled tubulars machined from solid steel bars and manufactured to specifications to meet and/or exceed API or NS-1 requirements. The quality of the heat treatment is critical in the production of raw materials and must be uniform and deep enough through the thickness of the bar to ensure the mechanical properties.

Drill collars are used as a component of the bottom-hole assembly (BHA) and provide the following:

- Drilling weight-on-bit (WOB)
- BHA directional control
- Hole size integrity
- Stiffness to maintain hole straightness
- Clearance for the drill string
- Compressive and torsional loads
- Mitigate differential sticking and stuck pipe thanks to spiraled grooves



Standard:

- ODs from 2-7/8" to 11"
- API 7.1 & 7.2 specifications
- Slick or spiraled
- API & H90 connections
- Fatigue resistance features (threads cold rolled, API pin stress relief groove, and API box bore-back)
- Range 2 and 3 lengths
- Phosphate coated threads
- Slip and elevator recess
- Pressed steel thread protectors
- A variety of steel grades: API, Sour Service, NS1, Low Temp, Non Magnetic

Options:

- Hard banding
- Internal plastic coating for OD <6 1/2"
- High-performance double shoulder connections upon request
- Customized elevator and slip recess
- NS-1 or DS-1 or customers specifications
- Make and Break

Stabilizers

Stabilizers are used to prevent undesirable deviation of the drill string. Typically, one or two stabilizers are placed in the bottom-hole assembly (BHA) to increase drill string stability. Additional stabilizers can be added to the drill string to further improve BHA solidness and minimize wellbore deviation.

Full quality control procedures are maintained throughout all production processes; when hard-facing is applied, final ultrasonic inspection is carried out to ensure that a minimum of 97% bonding of carbide inserts is obtained. It is our guarantee that each tool is certified to this effect. Connections also receive full dye penetrant inspection and are coated with an anti-galling treatment.



Material certificates, Certificates of Conformity and 3rd party inspection reports can be furnished to our customers for traceability.

Downhole Motor

Downhole motor is a kind of tool generally used for oil drilling that can convert hydraulic energy into mechanical energy through a conjugator of a stator a rotor.

The motors are usually used together with cone bits, diamond bits and so on in drilling courses, such as directional and vertical drilling, horizontal well drilling, correcting deviation, coring, reaming sidetracking, etc...

Downhole motors provide clear advantages for vertical drilling applications. They deliver an increased rate of penetration and better hole deviation control. Downhole motors also reduce drilling string failure rate, casing and drill pipe wear, wear and tear of the swivel, Kelly and rotary drives and fuel cost because less energy is required to power a mud motor. This means downhole performance motors can reduce your overall drilling costs and increase your drilling efficiency.



Oil Well Cement

Oil Well cement is produced during special campaigns of high sulfate resistance clinker. This is stocked separately from other product clinkers and the finished product is stored separately in a dedicated silo.

Well cement is specified using classes A, B, C, D, G and H and the grade ordinary (O), moderate Sulfate resistance (MSR) and high sulfate resistance (HSR).



Class "G"	Oil well Cement %	Specification %
Magnesium Oxide(MgO)	1.13	6.0 max
Sulfur Trioxide(SO ₃)	1.75	3.0 max
Loss on Ignition	1.63	3.0 max
Insoluble Residue	0.22	0.75 max
Tricalcium Silicate (C3S)	61.02	48.0 - 65.0
Tricalcium Aluminate (C3A)	0.54	3.0 max
C ₄ AF+2* C ₃ A	19.34	24 max
Total alkali content expressed as Sodium Oxide (Na ₂ O) equivalent	0.41	0.75 max

Physical Requirements		Specification
Fineness specific Surface (Kg/m ²)	314	Not specified
Free Fluid content (%)	4.5	5.9 max
Soundness Le-chatelier (mm)	1.0	Not specified
8 Hours Compressive Strength (Mpa)		
Curing Temp100°F(38°C)	4.1	Min 2.1
Curing Temp140°F(60°C)	12.0	Min 10.3
Thickening time (Schedule5)		
Maximum consistency 15-30 mints stirring period	11.0B _c	Max 30B _c
Time To reach 100 B _c Thickening time (minuets)	115	90 - 120

Elite

PROJECT ENGINEERING

Zhejiang Elite Project Engineering Co., Ltd.
Wenzhou Elite Flow Control Co., Ltd.

Corporate Headquarter:

Office No. 903, 9th Floor, Zhonggou International Office Building, Yangguangdadao Street., Oubei Town, Yongjia, Wenzhou, Zhejiang Province, People's Republic of China.

Tel: +86 (0) 577 66965398

Email: contact@eliteprojectengineering.com

Email: elite@eliteflowcontrol.com

China Manufacturing Facility:

No. 425, Zhangbao West Road, Dongou Industrial Zone, Oubei Street, Yongjia County, Wenzhou City, Zhejiang Province, People's Republic of China.

Email: sales@eliteflowcontrol.com

United Kingdom:

Unit 1, Winghay Close, Stoke-on-Trent, Staffordshire, England, ST6 4DU, United Kingdom.

Tel: +44 (0) 1782 978341 / +44 (0) 7465 965031

Email: efc@eliteflowcontrol.uk

Nigeria:

Suite # 204, 5, Force Road, Lagos Island, Opposite Tafawa Balewa, Lagos Island, Lagos, Nigeria.

Tel: +234 (0) 915 2248317

Email: nigeria@eliteflowcontrol.com

USA:

4840 Irvine Blvd Ste 205, Irvine, CA 92620, United States of America.

Tel: +1 (0) 514 594 1696

Email: contact@eliteprojectengineering.com

Canada:

28, Ferguson Street, Toronto, Canada.

Tel: +1 (0) 514 594 1696

Email: Sales.canada@eliteflowcontrol.com

Pakistan:

B 69, Block 18, KDA Scheme 24, Gulshan Iqbal, Karachi, Pakistan.

Tel: +92 213 4820542 / +92 (0) 332 3767598

Email: ah@eliteflowcontrol.com

